

RoHS Compliant 

THIS DRAWING CONTAINS INFORMATION THAT IS PROPRIETARY TO ZDT TECHNOLOGY. AND SHOULD NOT BE USED WITHOUT WRITTEN PERMISSION

REV	ECN No.	DATE	REMARK
A	NEW	2020.12.15	NEW RELEASE
B	---	2023.09.18	图框更新

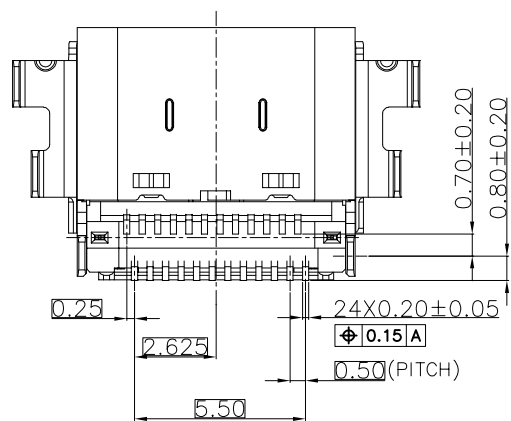
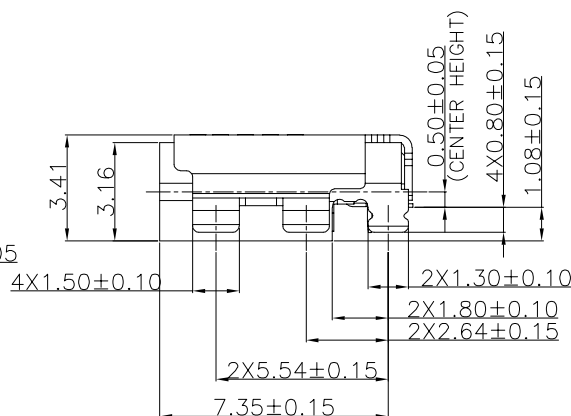
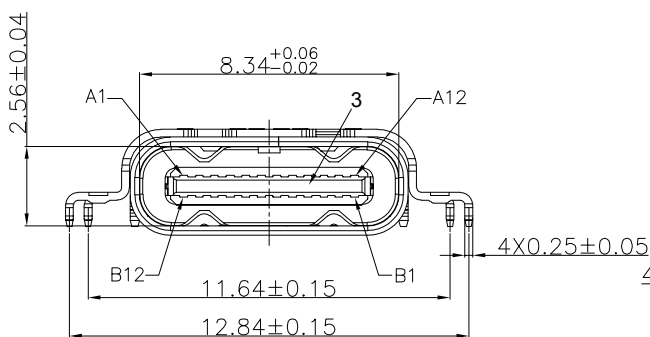
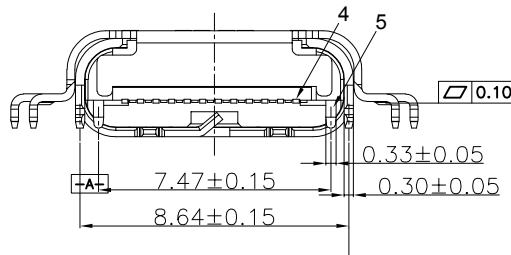
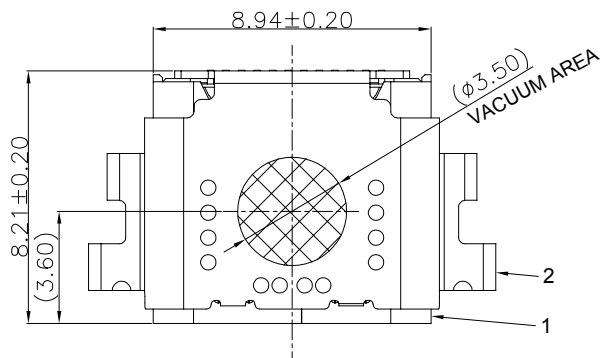

NOTE:
 1.ELECTRICAL PERFORMANCE,
 1-1. CURRENT RATING:5 AMPS. FOR TOTAL VBUS/GND PINS;
 1.25AMPS FOR CC PIN,0.25 AMPS. FOR ALL OTHER CONTACT.
 1-2. VOLTAGE RATING:5 V DC/AC (RMS. MAX)
 1-3. LLCR.:
 VBUS & GND PINS AND OTHER PINS: 40MΩ/PIN MAX.
 SHIELD:50MΩ/MAX.
 LLCR MAX. CHANGE OF ALL PINS: 10MΩ.
 1-4.INSULATION RESISTANCE: 100MΩ MIN
 1-5.DIELECTRIC WITHSTAND VOLTAGE,AC 100V FOR 1 MINUTE.
 2.MECHANICAL PERFORMANCE,
 2-1.INSERTION FORCE: 5~20N.
 2-2.EXTRACTION FORCE: 8~20N.
 2-3.DURABILITY: 10000 CYCLES.
 3.ENVIRONMENTAL PERFORMANCE:
 OPERATING TEMPERATURE: -25°C~+85°C.
 4.IR REFLOW:
 THE PEAK TEMPERATURE ON THE BOARD SHALL BE MAINTAINED FOR 10 SECONDS AT 260°C.
 5.COMPLIANCE WITH ROHS REQUIREMENTS.
 6.SALT SPRAY:48H
 7.PART NUMBER CODE:
 CF 3 24 - 013 S C B 12 R
 (1)(2) (3) (4) (5) (6)

(1) Product type:
 2-TOP-MOUNT
 3-MID-MOUNT
 (2) Pin No.:
 24:24Pin
 (3) HOUSING MATERIALS:
 C:PA9T
 (4) HOUSING COLOR:
 B:BLACK
 (5) CONTACTS PLATED:
 12:接触镀金3u"其它GF
 (6) PACKING OPTIONS
 R:TAPE & REEL

TABLE:

NO	PART	Q'TY	Material
1	SHELL	1	STAINLESS STEEL 304, NI 30u" MIN PLATED T=0.30
2	Mid Plate	1	STAINLESS STEEL 301, NI 30u" MIN PLATED T=0.12
3	CONTACT	24	COPPER STEEL C18400,Au3U" plated on contact area GF plated 50u"min on solder area; Nickel 50u"min underplating over all. T=0.12
4	HOUSING	1	PA9T HF 30%玻纤, UL94 V-0, 黑色

PART NO.:
 SEE THE PART NUMBER CODE

QUALITY SYMBOL	GENERAL TOLERANCES
	± ---
	± 0.10
	± 0.20
	± 0.30
	± ---

 深圳市中科兴达科技有限公司
 SHENZHEN ZDT TECHNOLOGY CO., LTD

TITLE
 USB 4.0 Type C24P母座有后盖双壳
 双贴SMT CH=0.5mm,L=8.21mm (F5)

	THIRD ANGLE PROJECTION	UNIT mm	SCALE 1:1	SHEET NO. 1 OF 2
--	------------------------	---------	-----------	------------------

DRAWN BY: SAM

CHECKED BY: JAY

APPROVED BY: JACKY

DWG.NO. CF324-013

frame size: A4

