

RoHS Compliant

THIS DRAWING CONTAINS INFORMATION THAT IS PROPRIETARY TO ZDT TECHNOLOGY, AND SHOULD NOT BE USED WITHOUT WRITTEN PERMISSION

REV	ECN No.	DATE	REMARK
A	NEW	2020.11.25	新版发行
B	---	2023.04.23	整理图面

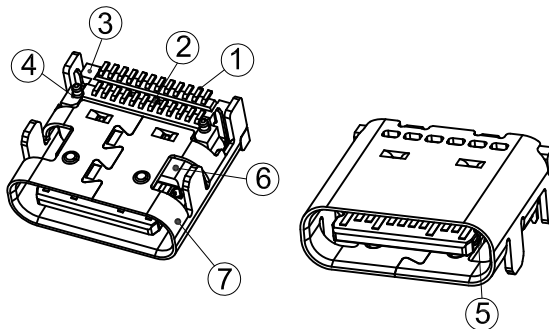
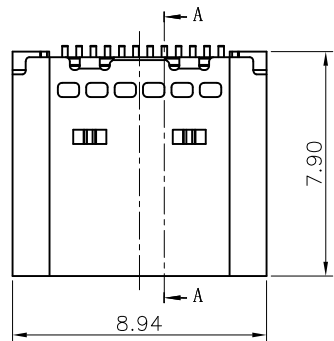

NOTE:
 1.MECHANICAL PERFORMANCE,
 1-1.INSERTION FORCE: 0.5~2.0kgf.
 1-2.REMOVAL FORCE: 0.8kgf~2.0kgf.
 1-3.DURABILITY: 10000 CYCLES.
 2.ELECTRICAL PERFORMANCE,
 2-1. CURRENT RATING:5.0A
 VOLTAGE RATING:20V
 2-2. LLCR:
 VBUS & GND PINS AND OTHER PINS: 40mΩ/PIN MAX.
 SHIELD: 50mΩ/MAX.
 LLCR MAX. CHANGE OF ALL PINS: 10mΩ.
 2-3.INSULATION RESISTANCE: 100MΩ MIN
 2-4.DIELECTRIC WITHSTAND VOLTAGE,AC 100V FOR 1 MINUTE.
 3.ENVIRONMENTAL PERFORMANCE:
 OPERATING TEMPERATURE: -25°C~+85°C.
 4.IR REFLOW:
 THE PEAK TEMPERATURE ON THE BOARD SHALL BE MAINTAINED FOR 10 SECONDS AT 260°C.
 5.符合ROHS&HF要求:

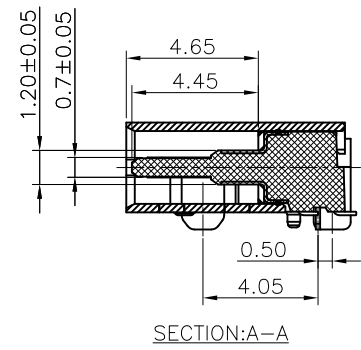
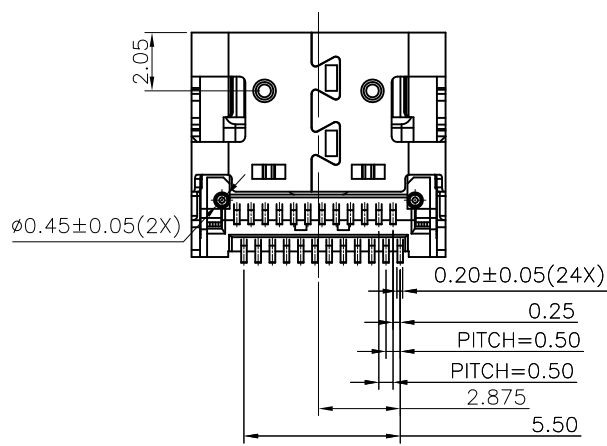
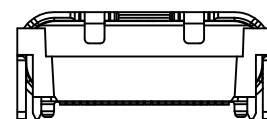
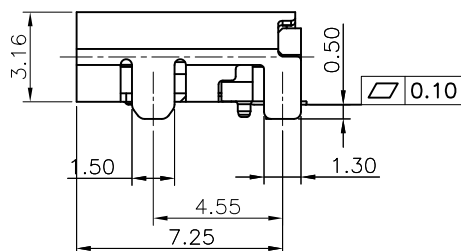
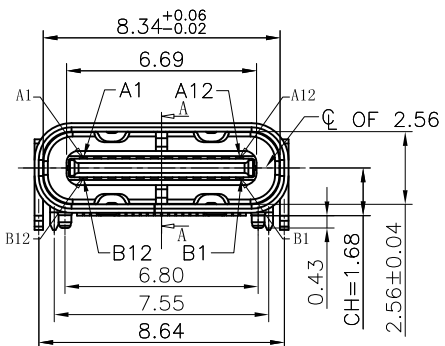

TID NO. 5200000273

TYPE:				
7	SHELL	1	SUS304 T=0.30 Ni 30u" MIN. UNDER PLATED OVER ALL.	
6	EMI	1	SUS304 T=0.10 Ni 30u" MIN. UNDER PLATED OVER ALL.	
5	SHIELDING PLATE	1	SUS301 T=0.15 Ni 30u" MIN. UNDER PLATED OVER ALL. Sn 80u"MIN. PLATED OVER ALL	
4	INSULATOR 2	1	LCP/PA9T UL94V-0 COLOR:BLACK	
3	INSULATOR 1	1	LCP/PA9T UL94V-0 COLOR:BLACK	
2	Down CONTACT	12	C18400 T=0.12 Ni 50u" MIN. UNDER PLATED OVER ALL	
1	TOP CONTACT	12	C18400 T=0.12 Au PLATED ON CONTACT,GF/Sn PLATED ON SOLDERING	
No.	PART NAME	Q'TY	MATERIAL	FINISH

PART NO.: SEE THE PART NUMBER CODE		ZDT 深圳市中科兴达科技有限公司 SHENZHEN ZDT TECHNOLOGY CO.,LTD		DRAWN BY SAM	DATE 2023.04.23
GENERAL TOLERANCES (UNLESS SPECIFIED)		TITLE USB C F 双排板上SMT有柱		CHECKED BY JAY	DATE 2023.04.23
QUALITY SYMBOL	x.xxxxx	±	---	APPROVED BY JACKY	DATE 2023.04.23
	x.xxx	±	0.10		
	x.xx	±	0.25		
	x.x	±	0.30		
	ANGULAR	±	---	THIRD ANGLE PROJECTION	
DWG.NO. ED-UC-009		SHEET NO. 1 OF 2		SCALE 1:1	
DIMENSION STYLE MM ONLY		DESIGN UNITS METRIC		frame size: A4	

RoHS Compliant

THIS DRAWING CONTAINS INFORMATION THAT IS PROPRIETARY TO ZDT TECHNOLOGY. AND SHOULD NOT BE USED WITHOUT WRITTEN PERMISSION

REV	ECN No.	DATE	REMARK
A	NEW	2020.11.25	新版发行
B	---	2023.04.23	整理图面

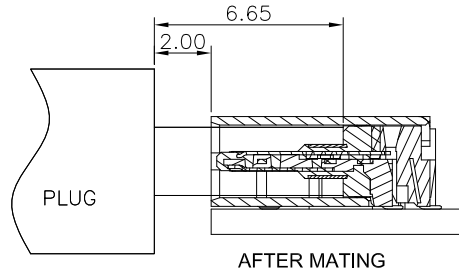

PART NUMBER CODE:

序号	PART NO.	REMARKS	PACKING
1	USF04-221212-023R	LCP黑色接触镀金3u"其它GF	TAPE & REEL
2	USF04-231212-023R	PA9T黑色接触镀金3u"其它GF	TAPE & REEL
3	USF04-221202-023R	LCP黑色半金锡3u"	TAPE & REEL
4	USF04-221214-023R	LCP黑色接触镀金15u"其它GF	TAPE & REEL
5	USF04-221215-023R	LCP黑色接触镀金30u"其它GF	TAPE & REEL
6	USF04-221212-023VR	LCP黑色接触镀金3u"其它GF	TAPE & REEL+真空包装

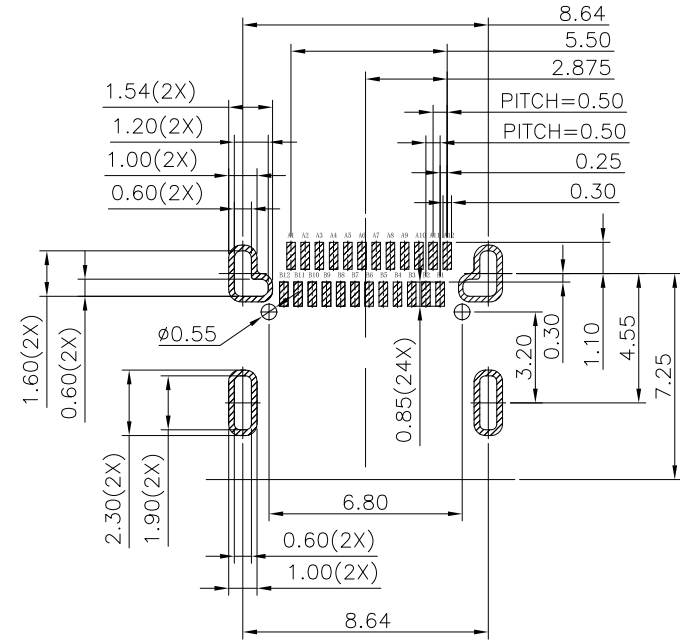

RECOMMENDED PCB LAYOUT(TOP VIEW)
THICKNESS 0.60MM;DEFAULT TOLERANCE:±0.05

PIN DEFINITION:

A1	A2	A3	A4	A5	A6	A7	A8	A9	A10	A11	A12
GND	TX1+	TX1-	VBUS	CC1	D+	D-	SBU1	VBUS	RX2-	RX2+	GND
GND	RX1+	RX1-	VBUS	SBU2	D-	D+	CC2	VBUS	TX2-	TX2+	GND
B12	B11	B10	B9	B8	B7	B6	B5	B4	B3	B2	B1

PART NO.: SEE THE PART NUMBER CODE		ZDT 深圳市中科兴达科技有限公司 SHENZHEN ZDT TECHNOLOGY CO., LTD		DRAWN BY SAM	DATE 2023.04.23	
QUALITY SYMBOL = 0	GENERAL TOLERANCES (UNLESS SPECIFIED)		TITLE USB C F 双排板上SMT有柱			
	x.xxxx	± ---	DWG.NO. ED-UC-009	SHEET NO. 2 OF 2	CHECKED BY JAY	DATE 2023.04.23
	x.xxx	± 0.10			APPROVED BY JACKY	DATE 2023.04.23
	x.xx	± 0.25	DIMENSION STYLE MM ONLY	DESIGN UNITS METRIC	SCALE 1:1	
x.x	± 0.30	THIRD ANGLE PROJECTION				
ANGULAR	± ---°	frame size: A4				