

10 9 8 7 6 5 4 3 2 1

RoHS Compliant  THIS DRAWING CONTAINS INFORMATION THAT IS PROPRIETARY TO ZDT TECHNOLOGY. AND SHOULD NOT BE USED WITHOUT WRITTEN PERMISSION

TYPE C协会认证TID NO. 3657

REV	ECN No.	DATE	REMARK
A	NEW	2016.04.14	新版发行
B	ECN1612001	2016.12.23	变更新料号
C	ECN1709005	2017.09.06	新增电镀15u规格
D	ECN1803005	2018.03.08	新增外壳镀金规格
E	ECN1805012	2018.05.29	镀金1u => 3u
F	ECN1908008	2019.08.05	变更新图号
G	ECN2011005	2020.11.09	升级第三代产品

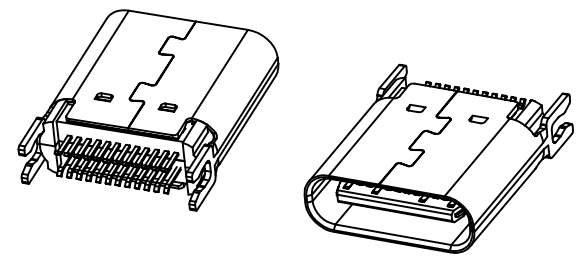
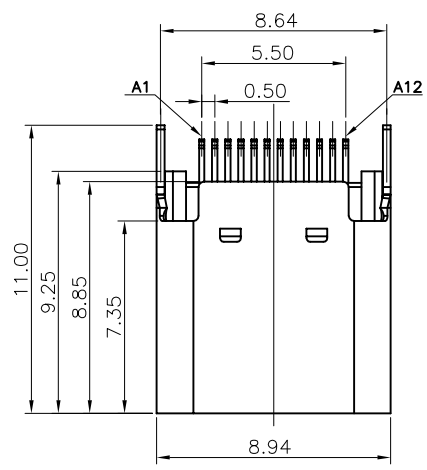



NOTE:

- MATERIAL SPECIFICATION:
 - HOUSING: HIGH TEMPERATURE RESISTANT PLASTIC PA9T, UL94 V-0.
 - CONTACTS: COPPER ALLOY T=0.12mm
 - MID PLATE: STAINLESS STEEL(SUS301)T=0.15mm
 - EMI PLATE: STAINLESS STEEL(SUS301)T=0.10mm
 - SHELL: STAINLESS STEEL(SUS304)T=0.30mm
- PLATING SPECIFICATION:
 - CONTACTS:
 - 50u" MIN. UNDER PLATED OVER ALL.
 - Au PLATED ON THE FUNCTIONAL AREA OF CONTACT. (GOLD PLATING THICKNESS FOLLOW THE P/N)
 - FRONT SHELL&OUTER SHELL:
 - 30u" MIN. UNDER PLATED OVER ALL.
 - MID PLATE:
 - 30u" MIN. UNDER PLATED OVER ALL.
 - Sn 80u" MIN. PLATED OVER ALL
 - EMI PLATE:
 - CLEAR ONLY
- MECHANICAL PERFORMANCE:
 - INSERTION FORCE: 0.5~2.0kgf.
 - REMOVAL FORCE: 0.8kgf~2.0kgf.
 - DURABILITY: 10000 CYCLES.
- ELECTRICAL PERFORMANCE:
 - CURRENT RATING: 5.0V VOLTAGE RATING: 5.0V
 - LLCR:
 - VBUS & GND PINS AND OTHER PINS: 40mΩ/PIN MAX.
 - SHIELD: 50mΩ/MAX.
 - LLCR MAX. CHANGE OF ALL PINS: 10mΩ.
 - INSULATION RESISTANCE: 100MΩ MIN
 - DIELECTRIC WITHSTAND VOLTAGE, AC 100V FOR 1 MINUTE.
- ENVIRONMENTAL PERFORMANCE:
 - OPERATING TEMPERATURE: -25°C~+85°C.
- IR REFLOW:
 - THE PEAK TEMPERATURE ON THE BOARD SHALL BE MAINTAINED FOR 10 SECONDS AT 260°C.
- PART NUMBER CODE: (产品料号)

Z-CF009 X X B XX T-A-01
(1)(2)(3)(4)

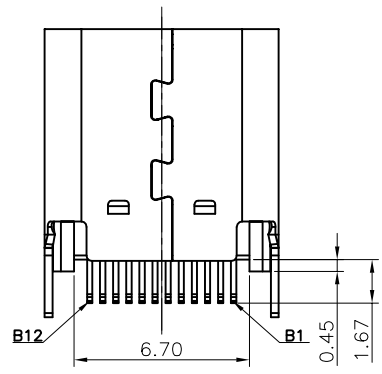
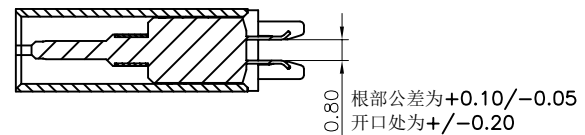
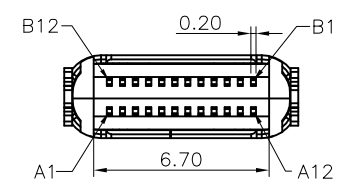
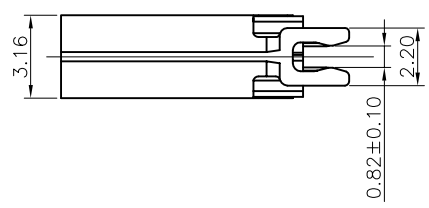
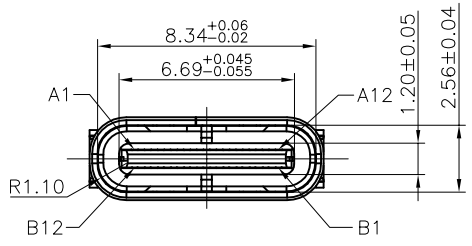
- (1) SHELL PLATED: S:NI J:BLACK Ni
- (2) HOUSING MATERIAL: L:PA9T
- (3) HOUSING COLOR: B:BLACK
- (4) CONTACTS PLATED: 02:半金铜3u" 05:半金铜30u"
- (5) PACKING OPTIONS T:TUBE



PART NO.: SEE THE PART NUMBER CODE		ZDT 深圳市中科兴达科技有限公司 SHENZHEN ZDT TECHNOLOGY CO., LTD		DRAWN BY SAM	DATE 2020.11.09
QUALITY SYMBOL 0  0	GENERAL TOLERANCES (UNLESS SPECIFIED)		TITLE USB C F TYPE母座夹板0.8短体9.3		
	x.xxxx	± ---	DWG.NO. CF009-01	SHEET NO. 1 OF 3	
	x.xxx	± 0.10		CHECKED BY JAY	
	x.xx	± 0.25		DATE 2020.11.09	
x.x	± 0.30	APPROVED BY JACKY			
ANGULAR	± ---°	DIMENSION STYLE MM ONLY		DESIGN UNITS METRIC	SCALE 1:1
THIRD ANGLE PROJECTION					

frame size: A4

10 9 8 7 6 5 4 3 2 1

RoHS Compliant  THIS DRAWING CONTAINS INFORMATION THAT IS PROPRIETARY TO ZDT TECHNOLOGY. AND SHOULD NOT BE USED WITHOUT WRITTEN PERMISSION

TYPE C协会认证TID NO. 3657

REV	ECN No.	DATE	REMARK
A	NEW	2016.04.14	新版发行
B	ECN1612001	2016.12.23	变更新料号
C	ECN1709005	2017.09.06	新增电镀15u规格
D	ECN1803005	2018.03.08	新增外壳镀金规格
E	ECN1805012	2018.05.29	镀金1u => 3u
F	ECN1908008	2019.08.05	变更新图号
G	ECN2011005	2020.11.09	升级第三代产品

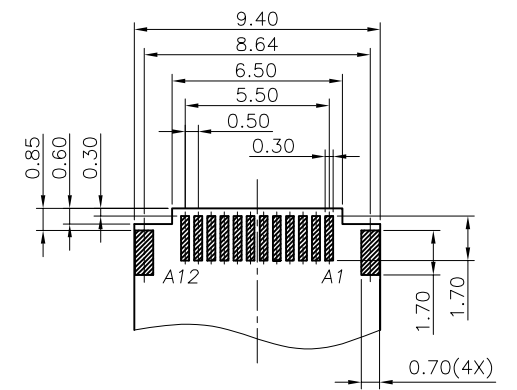
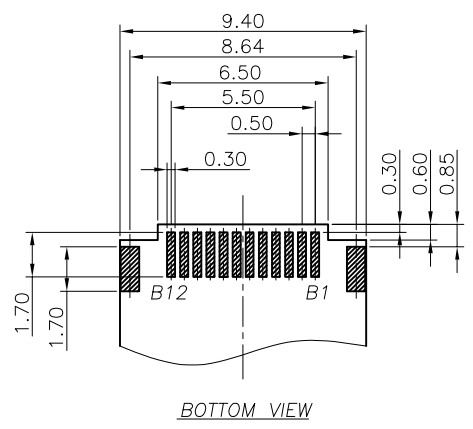
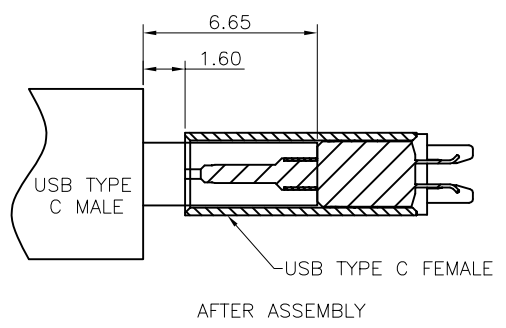

USB TYPE-C PIN ASSIGNMENTS

PIN NUMBER	SIGNAL NAME	PIN NUMBER	SIGNAL NAME
A1	GND	B12	GND
A2	SSTXp1	B11	SSRXp1
A3	SSTXn1	B10	SSRXn1
A4	Vbus	B9	Vbus
A5	CC1	B8	SBU2
A6	Dp1	B7	Dn2
A7	Dn1	B6	Dp2
A8	SBU1	B5	CC2
A9	Vbus	B4	Vbus
A10	SSRXn2	B3	SSTXn2
A11	SSRXp2	B2	SSTXp2
A12	GND	B1	GND

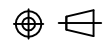
PART NO.: SEE THE PART NUMBER CODE		 深圳市中科兴达科技有限公司 SHENZHEN ZDT TECHNOLOGY CO., LTD		DRAWN BY SAM	DATE 2020.11.09	
QUALITY SYMBOL 0 ∇ 0	GENERAL TOLERANCES (UNLESS SPECIFIED)		TITLE USB C F TYPE母座夹板0.8短体9.3			
	x.xxxx	± ---	DWG.NO. CF009-01	SHEET NO. 2 OF 3	CHECKED BY JAY	DATE 2020.11.09
	x.xxx	± 0.10			APPROVED BY JACKY	DATE 2020.11.09
	x.xx	± 0.25	DIMENSION STYLE MM ONLY	DESIGN UNITS METRIC	SCALE 1:1	
x.x	± 0.30			 THIRD ANGLE PROJECTION		
ANGULAR	± ---°					

10 9 8 7 6 5 4 3 2 1

RoHS Compliant  THIS DRAWING CONTAINS INFORMATION THAT IS PROPRIETARY TO ZDT TECHNOLOGY. AND SHOULD NOT BE USED WITHOUT WRITTEN PERMISSION

REV	ECN No.	DATE	REMARK
A	NEW	2016.04.14	新版发行
B	ECN1612001	2016.12.23	变更新料号
C	ECN1709005	2017.09.06	新增电镀15u规格
D	ECN1803005	2018.03.08	新增外壳镀金规格
E	ECN1805012	2018.05.29	镀金1u => 3u
F	ECN1908008	2019.08.05	变更新图号
G	ECN2011005	2020.11.09	升级第三代产品

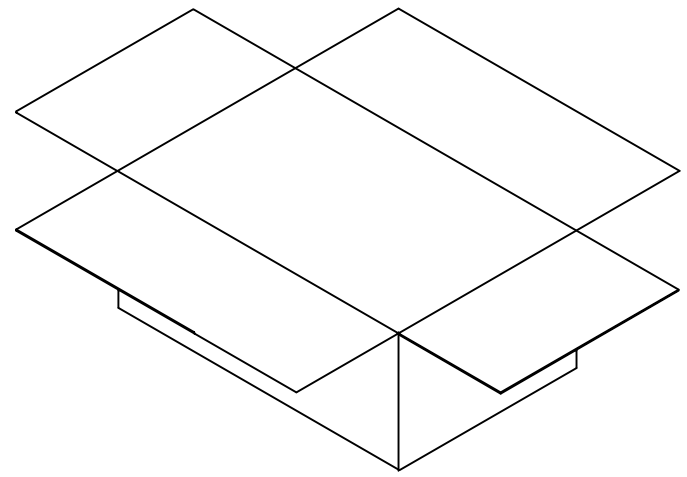
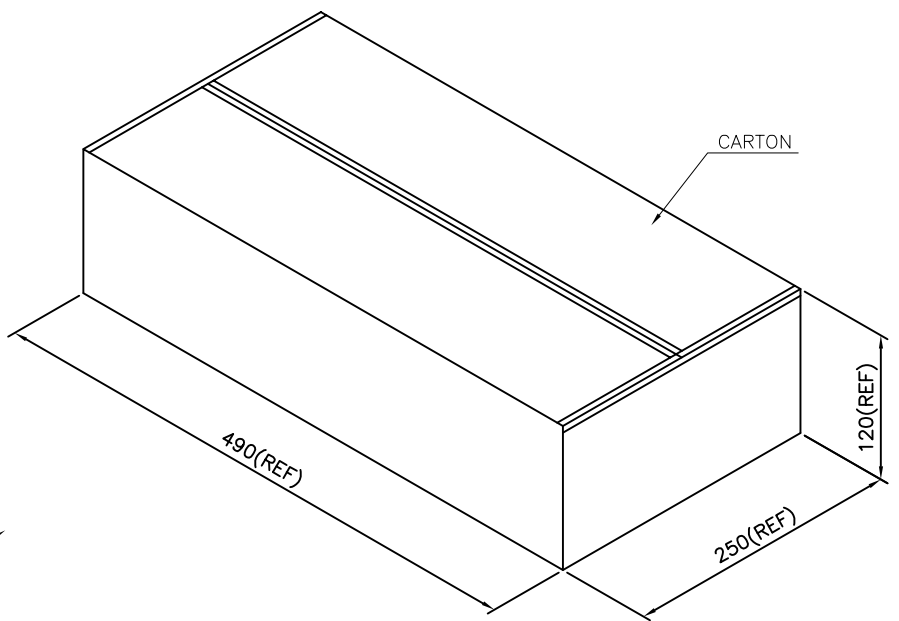
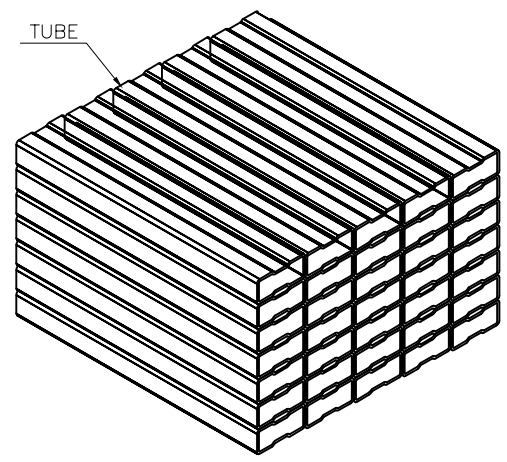
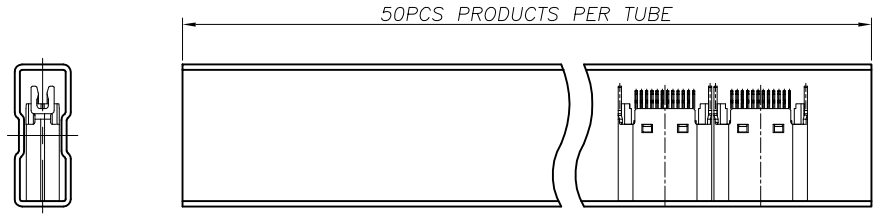

	TUBE	CARTON
CONNECTOR (PCS)	50	18000

PART NO.: SEE THE PART NUMBER CODE		ZDT 深圳市中科兴达科技有限公司 SHENZHEN ZDT TECHNOLOGY CO., LTD		DRAWN BY SAM	DATE 2020.11.09
QUALITY SYMBOL 0 ∇ 0		GENERAL TOLERANCES (UNLESS SPECIFIED)		TITLE USB C F TYPE母座夹板0.8短体9.3	
		x.xxxx	± ---	DWG.NO. CF009-01	
x.xxx	± 0.10	SHEET NO. 3 OF 3		CHECKED BY JAY	
x.xx	± 0.25			DATE 2020.11.09	
x.x	± 0.30	APPROVED BY JACKY		DATE 2020.11.09	
ANGULAR	± ---°	DIMENSION STYLE MM ONLY	DESIGN UNITS METRIC	SCALE 1:1	
 THIRD ANGLE PROJECTION					