



10 9 8 7 6 5 4 3 2 1

RoHS Compliant  THIS DRAWING CONTAINS INFORMATION THAT IS PROPRIETARY TO ZDT TECHNOLOGY, AND SHOULD NOT BE USED WITHOUT WRITTEN PERMISSION

REV	ECN No.	DATE	REMARK
A	NEW	2015.05.10	NEW RELEASE



Compression capacity of shell panel to sealing ring 0.30min

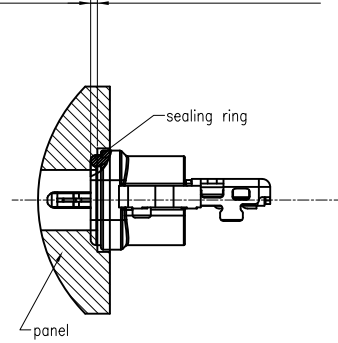

Assembly Sketch Map

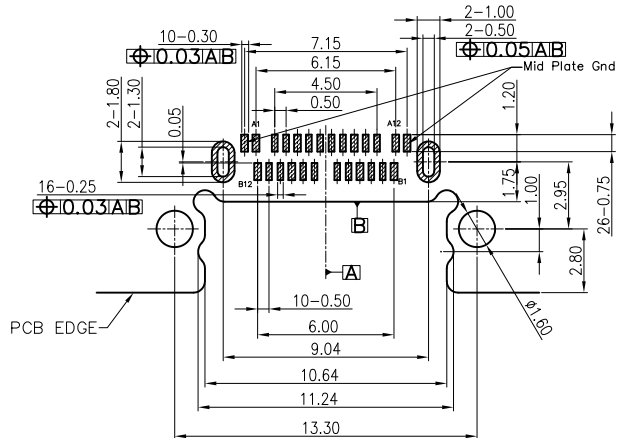

RECOMMENDED P.C.B LAYOUT (COMPONENT SIDE)

PCB THICKNESS: 0.80±0.05mm  
DEFAULT TOLERANCE: ±0.05mm

PART NO.: SEE THE PART NUMBER CODE		<b>ZDT</b> 深圳市中科兴达科技有限公司 SHENZHEN ZDT TECHNOLOGY CO., LTD		DRAWN BY SAM	DATE 2015.05.10	
QUALITY SYMBOL 0 0 0 0 0	GENERAL TOLERANCES (UNLESS SPECIFIED)		TITLE Type CF 24pin 沉板2.0 (舌片外漏带耳IPX8防水)			
	x.xxxx	± ---	DWG.NO. CFW24-002-F8	SHEET NO. 2 OF 3	CHECKED BY JAY	DATE 2015.05.10
	x.xxx	± 0.10			APPROVED BY JACKY	DATE 2015.05.10
	x.xx	± 0.25	DIMENSION STYLE MM ONLY		DESIGN UNITS METRIC	SCALE 1:1
	x.x	± 0.30	THIRD ANGLE PROJECTION			
ANGULAR	± ---°	frame size: A4				

10 9 8 7 6 5 4 3 2 1

RoHS Compliant

THIS DRAWING CONTAINS INFORMATION THAT IS PROPRIETARY TO ZDT TECHNOLOGY, AND SHOULD NOT BE USED WITHOUT WRITTEN PERMISSION

REV	ECN No.	DATE	REMARK
A	NEW	2015.05.10	NEW RELEASE

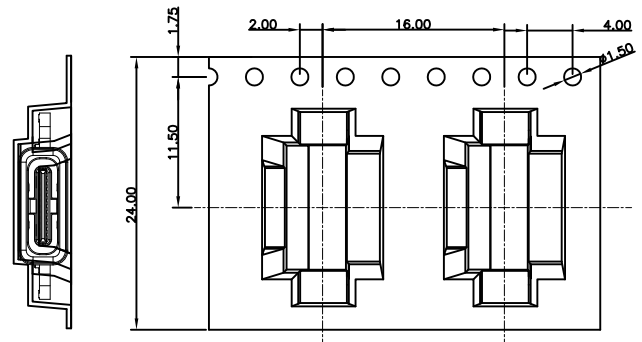
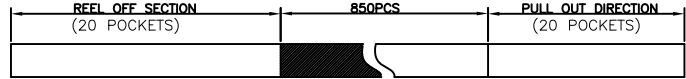

← PRODUCT PACKAGING DIRECTION  
 CUSTOMER TO USE DIRECTION →

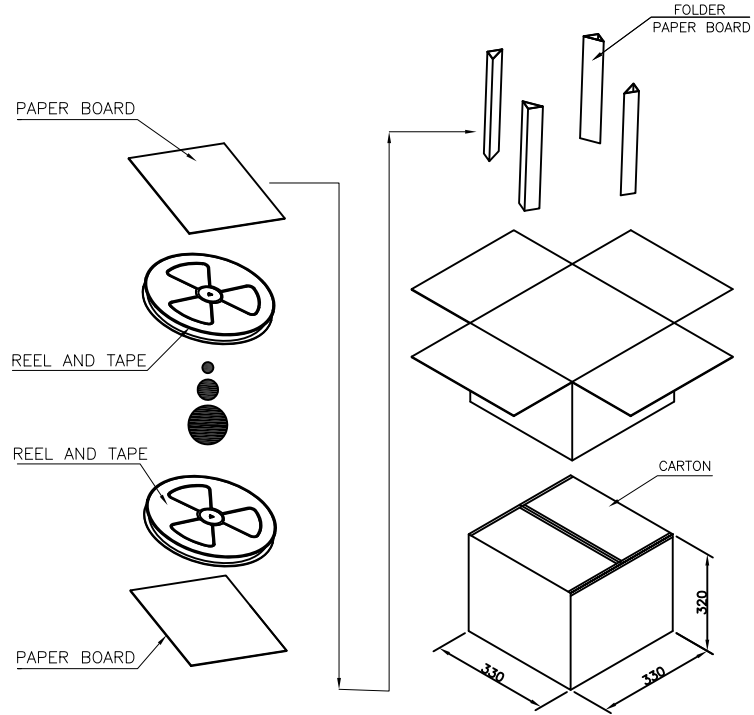
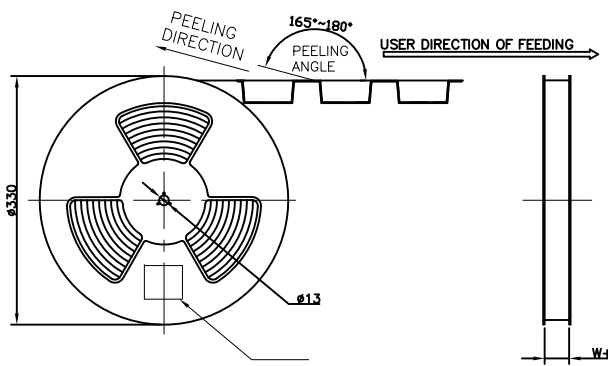

CONN. QTY./REEL	REEL QTY./CARTON	CONN. QTY./CARTON
850	10	8500 PCS

PART NO.: SEE THE PART NUMBER CODE		<b>ZDT</b> 深圳市中科兴达科技有限公司 SHENZHEN ZDT TECHNOLOGY CO., LTD		DRAWN BY SAM	DATE 2015.05.10
GENERAL TOLERANCES (UNLESS SPECIFIED)		TITLE Type CF 24pin 沉板2.0 (舌片外漏带耳IPX8防水)		CHECKED BY JAY	DATE 2015.05.10
QUALITY SYMBOL	$\Delta$	x:xxxx	±	DWG.NO. CFW24-002-F8	SHEET NO. 3 OF 3
	$\nabla$	x.xxx	± 0.10	DIMENSION STYLE MM ONLY	DESIGN UNITS METRIC
	$\square$	x.xx	± 0.25	SCALE 1:1	APPROVED BY JACKY
	$\blacktriangledown$	x.x	± 0.30	DATE 2015.05.10	
	ANGULAR		±	THIRD ANGLE PROJECTION	

10 9 8 7 6 5 4 3 2 1 frame size: A4