

RoHS Compliant

THIS DRAWING CONTAINS INFORMATION THAT IS PROPRIETARY TO ZDT TECHNOLOGY. AND SHOULD NOT BE USED WITHOUT WRITTEN PERMISSION

TID NO. 10017

REV	ECN No.	DATE	REMARK
A	NEW	2023.04.12	NEW RELEASE
B	---	2023.06.26	新增不带LOGO规格
C	---	2023.09.25	整理图纸

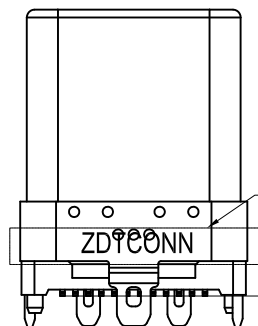
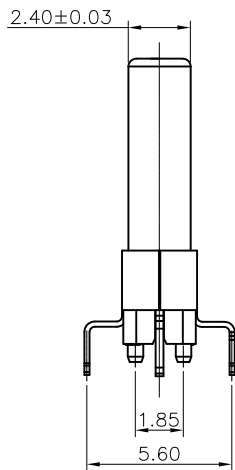
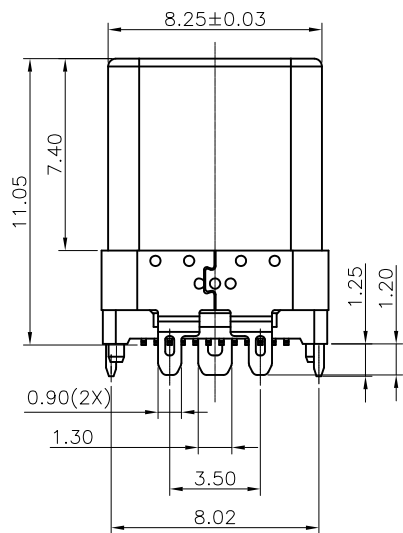
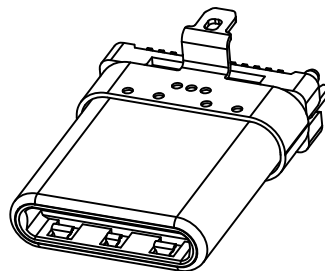
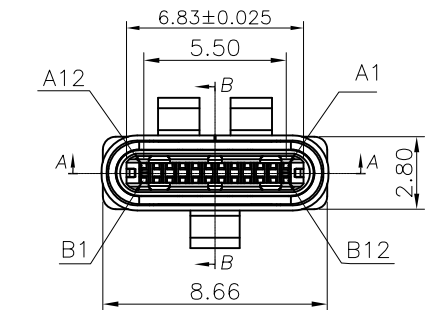

With/Without "Logo" See The PART NUMBER CODE

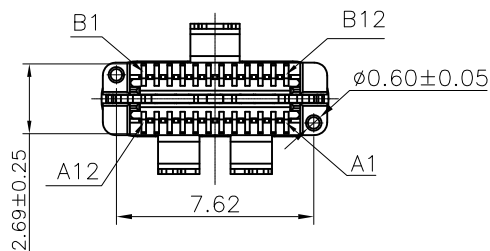

NOTE:

- ELECTRICAL PERFORMANCE,
 - CURRENT RATING:5 AMPS. FOR TOTAL VBUS/GND PINS; 1.25AMPS FOR CC PIN,0.25 AMPS. FOR ALL OTHER CONTACT.
 - VOLTAGE RATING:5V/20V DC/AC (RMS. MAX)
 - LLCR:
 - VBUS & GND PINS AND OTHER PINS: 40MΩ/PIN MAX.
 - SHIELD:50MΩ/MAX.
 - LLCR MAX. CHANGE OF ALL PINS: 10MΩ.
 - INSULATION RESISTANCE: 100MΩ MIN
 - DIELECTRIC WITHSTAND VOLTAGE,AC 100V FOR 1 MINUTE.
- MECHANICAL PERFORMANCE,
 - INSERTION FORCE: 5~20N.
 - EXTRACTION FORCE: 8~20N.
 - DURABILITY: 10000 CYCLES.
- ENVIRONMENTAL PERFORMANCE:
 - OPERATING TEMPERATURE: -25°C~+85°C.
- IR REFLOW:
 - THE PEAK TEMPERATURE ON THE BOARD SHALL BE MAINTAINED FOR 10 SECONDS AT 260°C.
- COMPLIANCE WITH ROHS&HF REQUIREMENTS.

6.PART NUMBER CODE:

CM 24 011 S L B 02 R - X
(1) (2) (3) (4) (5) (6)

- Pin No.: 24:24Pin
- HOUSING MATERIALS: L:LCP
- HOUSING COLOR: B:BLACK
- CONTACTS PLATED: 02:半金锡3u
- PACKING OPTIONS: R:TAPE & REEL
- SHEEL LOGO Option: 无:外壳带ZDT LOGO 1:外壳无ZDT LOGO

TABLE:

ITEM	NAME	QTY.	MATERIAL	DESCRIPTION
7	CAP	1	LCP UL94V-0	Color: Black
6	Back Shell	1	Stainless Steel SUS304 T=0.20	NICKEL 30U" MIN PLATED
5	Housing	4	LCP UL94V-0	Color: Black
4	Latch	1	Stainless Steel SUS301 T=0.30	Tin plated 80u"min on solder area; Nickel 50u"min underplating over all.
3	Contact	24	Copper Alloy C7025 T=0.15	3u"gold plated on Contact area, Matte Tin plated on Soldertails, Nickel underplating over all
2	Emc Spring	2	Stainless Steel SUS304 T=0.10	
1	Front Shell	1	Stainless Steel SUS316L T=0.15	NICKEL 30U" MIN PLATED

PART NO.:

SEE THE PART NUMBER CODE

深圳市中兴科达科技有限公司
SHENZHEN ZDT TECHNOLOGY CO., LTD

DRAWN BY: SAM

QUALITY SYMBOL	GENERAL TOLERANCES	TITLE
○	x.xxxx ± ---	USB TYPE-C PLUG 24PIN VERTICAL, SMT H=11.1cm, SOLDER TAB=1.25mm(02)
▽	x.xxx ± 0.10	
△	x.xx ± 0.25	
□	x.x ± 0.30	
▲	ANGULAR ± ---°	

THIRD ANGLE PROJECTION

UNIT	SCALE	SHEET NO.	DWG.NO.
mm	1:1	1 OF 2	CM24011

CHECKED BY: JAY

APPROVED BY: JACKY

DWG.NO. CM24011

frame size: A4

RoHS Compliant 

THIS DRAWING CONTAINS INFORMATION THAT IS PROPRIETARY TO ZDT TECHNOLOGY. AND SHOULD NOT BE USED WITHOUT WRITTEN PERMISSION

TID NO. 10017

REV	ECN No.	DATE	REMARK
A	NEW	2023.04.12	NEW RELEASE
B	---	2023.06.26	新增不带LOGO规格
C	---	2023.09.25	整理图纸

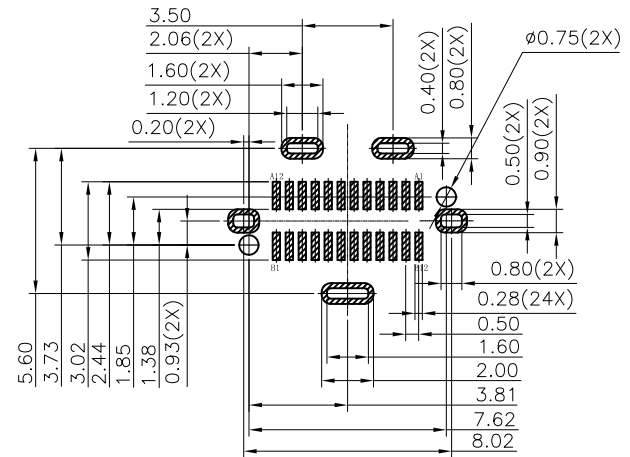

RECOMMENDED PCB LAYOUT(TOP VIEW)
THICKNESS 0.8±0.10MM;DEFAULT TOLERANCE:±0.05

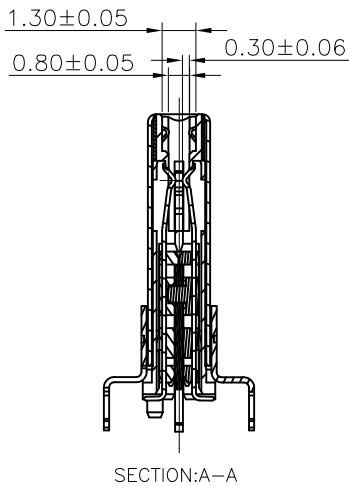
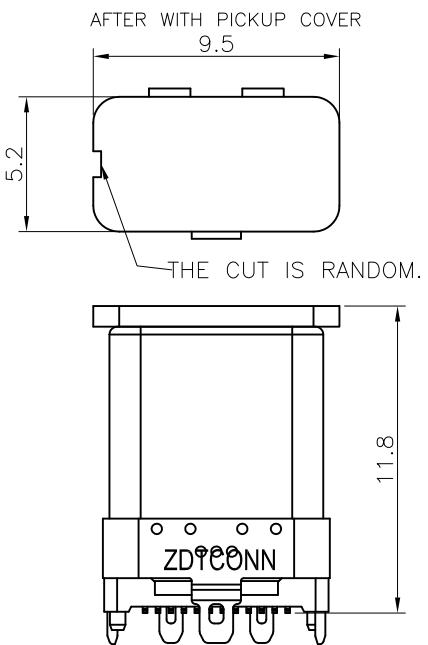

USB TYPE-C PIN ASSIGNMENTS

PIN NUMBER	SIGNAL NAME	PIN NUMBER	SIGNAL NAME
A1	GND	B12	GND
A2	SSTXp1	B11	SSRXp1
A3	SSTXn1	B10	SSRXn1
A4	Vbus	B9	Vbus
A5	CC1	B8	SBU2
A6	Dp1	B7	Dn2
A7	Dn1	B6	Dp2
A8	SBU1	B5	CC2
A9	Vbus	B4	Vbus
A10	SSRXn2	B3	SSTXn2
A11	SSRXp2	B2	SSTXp2
A12	GND	B1	GND

PART NO.: SEE THE PART NUMBER CODE		 深圳市中科兴达科技有限公司 SHENZHEN ZDT TECHNOLOGY CO., LTD		DRAWN BY: SAM	
QUALITY SYMBOL	0	GENERAL TOLERANCES		CHECKED BY: JAY	
	▽	x.xxxx	± ---	APPROVED BY: JACKY	
	▽	x.xxx	± 0.10	DWG.NO. CM24011	
	▽	x.xx	± 0.25	frame size: A4	
	▽	x.x	± 0.30		
▲	ANGULAR	± ---			
TITLE		THIRD ANGLE PROJECTION	UNIT mm	SCALE 1:1	SHEET NO. 2 OF 2
USB TYPE-C PLUG 24PIN VERTICAL, SMT H=11.1cm, SOLDER TAB=1.25mm(O2)					