

RoHS Compliant

THIS DRAWING CONTAINS INFORMATION THAT IS PROPRIETARY TO ZDT TECHNOLOGY, AND SHOULD NOT BE USED WITHOUT WRITTEN PERMISSION

REV	ECN No.	DATE	REMARK
A	NEW	2022.11.01	NEW RELEASE
B	---	2023.06.06	CM12001-02=> CM512-009-02

NOTES:

- MECHANICAL: (机械性能)
 - MATING FORCE: 5-20N .
插入力: 5-20N .
 - UNMATING FORCE: 8-20N
拔出力: 8-20N .
 - DURABILITY: 10000 CYCLES
耐久: 10000次
- ELECTRICAL: (电气性能)
 - CONTACT CURRENT RATING: 1.25A/PIN FOR VBUS AND GND, 0.25A/PIN FOR ALL OTHER CONTACT.
电流: 对VBUS和GND为1.25A/PIN, 其它为0.25A/PIN.
 - DIELECTRIC WITHSTANDING VOLTAGE: 100V AC AT SEA LEVEL.
耐电压: 100V AC AT SEA LEVEL.
 - LOW LEVEL CONTACT RESISTANCE: 40mΩ MAX FOR VBUS AND GND, 50mΩ MAX FOR OTHER CONTACTS.
接触阻抗: VBUS和GND, 40mΩ 最大; 其它为50mΩ.
 - INSULATION RESISTANCE: 100MΩ MIN AT 250VDC.
绝缘阻抗: 在电压250VDC, 100MΩ 最小.
 - OPERATING TEMPRATUR: -55~85°. E
- COMPLANARITY OF SMT TERMINAL IS 0.10MAX.
焊接端子平面度最大不超过0.10MM.

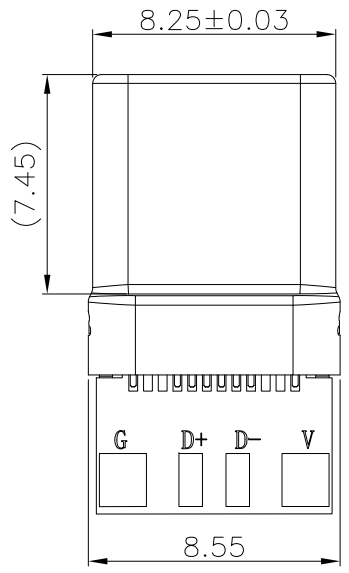
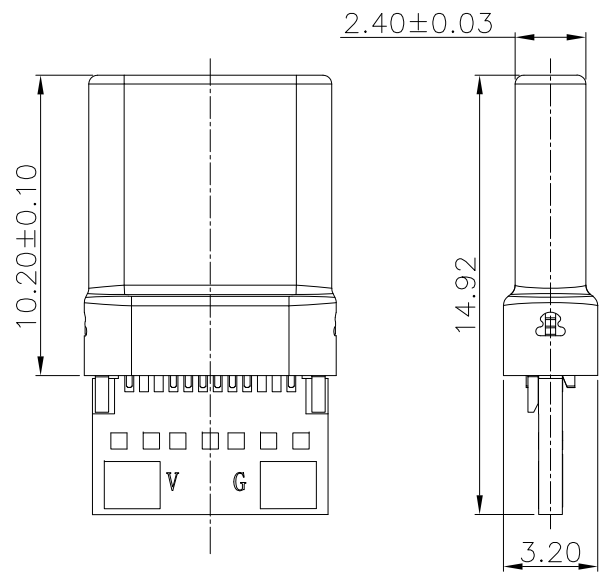
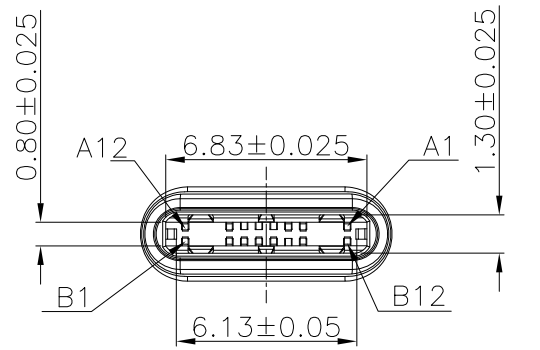

4.PART NUMBER CODE:
 CM 512 - 009 S L B 01 U - 02
 (1)(2)(3)(4)

(1) HOUSING MATERIALS:
L:LCP

(2) HOUSING COLOR:
B:BLACK

(3) CONTACTS PLATED:
01:接触镀金1u"焊接区雾锡GF

(4) PACKING OPTIONS
U:管装

TABLE:

No.	NAME	Q'TY	MATERIAL	FINISH
8	电阻	1PCS	56KΩ	
7	PCB	1PCS	绿色	
6	SPRING	1PCS	SUS 301 T=0.35	SPRING卡勾: SUS301;T=0.4, 半雾锡
5	TERMINAL	24PCS	C7025 T=0.20	模底50-150U, 锡100-200U, 接触点镀金
4	EMI PLATE	2PCS	SUS 304 T=0.08	清洗
3	FRONT SHELL	1PCS	SUS 316L T=0.15	喷砂镍50U'
2	EMI-Molding	2PCS	LCP BLACK UL94-V0	LCP BLACK UL94-V0
1	TERMINAL-Molding	2PCS	LCP BLACK UL94-V0	LCP BLACK UL94-V0
No.	NAME	Q'TY	MATERIAL	FINISH

线路原理图	
PLUG端	PCB焊盘
A1, A12, B1, B12, Shell	GND
A4, A9, B4, B9	VBUS
A5	
A6	Dp1
A7	Dn1

电阻 56K

PART NO.:
SEE THE PART NUMBER CODE

QUALITY SYMBOL	GENERAL TOLERANCES (UNLESS SPECIFIED)	
	x.xxxxx	± ---
	x.xxx	± 0.10
	x.xx	± 0.20
	x.x	± 0.30
ANGULAR	± ---°	

深圳市中兴科达科技有限公司
SHENZHEN ZDT TECHNOLOGY CO., LTD

TITLE
TYPE C 公头12P插Pin款2.0 A-C

DWG.No. CM512-009-02 SHEET No. 1 OF 1

DIMENSION STYLE: MM ONLY DESIGN UNITS: METRIC SCALE: 1:1

DRAWN BY: SAM DATE: 2023.06.06

CHECKED BY: JAY DATE: 2023.06.06

APPROVED BY: JACKY DATE: 2023.06.06

THIRD ANGLE PROJECTION

frame size: A4