

RoHS Compliant 

THIS DRAWING CONTAINS INFORMATION THAT IS PROPRIETARY TO ZDT TECHNOLOGY. AND SHOULD NOT BE USED WITHOUT WRITTEN PERMISSION

REV	ECN No.	DATE	REMARK
A	NEW	2020.12.15	NEW RELEASE
B	ENC202308026	2023.08.26	图框变更

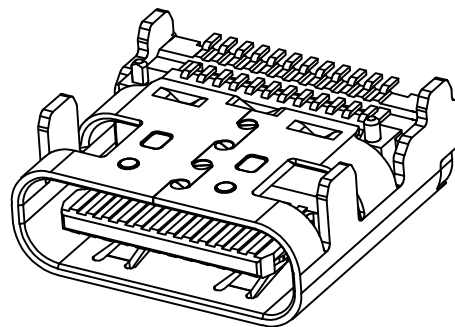

NOTE/注释:

1. SPECIFICATION/规格:

- 1.1 Rated current (额定电流): 5.0 A
- 1.2 Voltage rating (额定电压): 5V AC
- 1.3 Contact Resistance (接触阻抗): 40 m Ω Max.
- 1.4 Insulation Resistance (绝缘阻抗): 100MΩ Min.
- 1.5 Withstanding voltage (耐电压): 100 VAC/minute
- 1.6 Mating force (插入力): 5~20N .
- 1.7 Unmating force (拔出力): 8~20N.
- 1.8 Durability Cycle(寿命循环):10,000 cycle
- 1.9 Operating temperature (工作温度): -40°~+85°

2.PART NUMBER CODE:

CF 2 24 - 010 S X B XX R
(1) (2) (3)(4)(5) (6)

- (1) 产品形态:
2:板上型
- (2) Pin No.:
24:24Pin
- (3) HOUSING MATERIALS:
C:PA9T
- (4) HOUSING COLOR:
B:BLACK
- (5) CONTACTS PLATED:
12:接触镀金3u", 其它GF
- (6) PACKING OPTIONS
R:TAPE & REEL

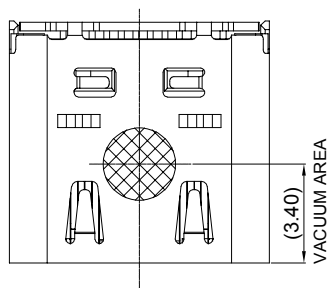

VACUUM AREA
(3.40)

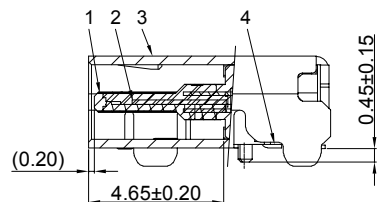
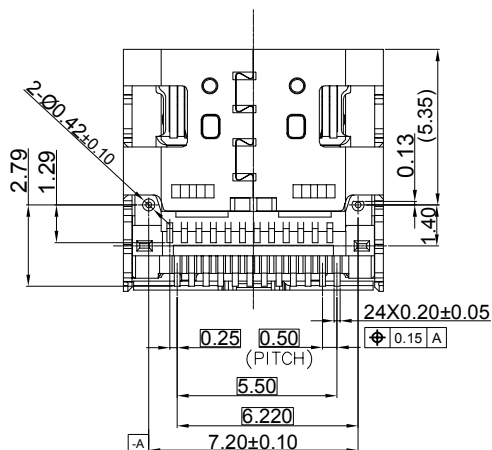
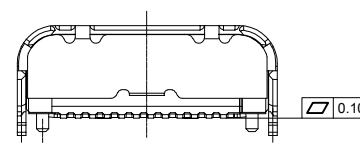
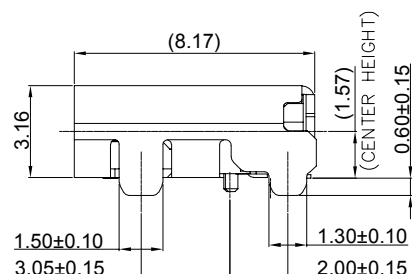
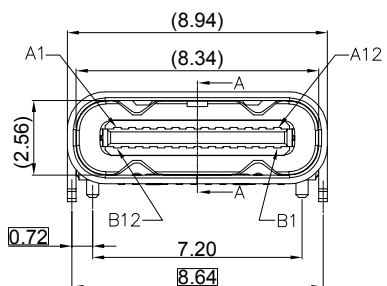

ITEM	DESCRIPTION	QTY	MATERIAL	FINISH	REMARK
4	TERMINAL	24	C18140	MATING SIDE:SEE PART NO; SOLDER TAIL:Gold FLASH, 50u" NICKEL OVERALL.	T=0.12
3	SHELL	1	SUS304	NICKEL PLATING	T=0.30
2	MID PLATE	1	SUS301	NICKEL PLATING	T=0.15
1	MAIN HOUSING	1	PA9T HF 30%玻纤, UL94 V-0, 黑色		BLACK UL94V-0

PART NO.:		SEE THE PART NUMBER CODE		ZDT 深圳市中科兴达科技有限公司 SHENZHEN ZDT TECHNOLOGY CO., LTD		DRAWN BY: SAM		
QUALITY SYMBOL	0	GENERAL TOLERANCES		TITLE USB 4.0 Type C 24P母座有后盖单壳 双贴SMT 板上平贴,L=8.17mm	THIRD ANGLE PROJECTION	UNIT mm	SCALE 1:1	
	0	x.xxxx	± ---					SHEET NO. 1 OF 3
	0	x.xxx	± 0.10					
	0	x.xx	± 0.25					
	0	x.x	± 0.30					
0	ANGULAR	± ---°						
				DWG.NO. CF224-010		frame size: A4		

RoHS Compliant

THIS DRAWING CONTAINS INFORMATION THAT IS PROPRIETARY TO ZDT TECHNOLOGY, AND SHOULD NOT BE USED WITHOUT WRITTEN PERMISSION

REV	ECN No.	DATE	REMARK
A	NEW	2020.12.15	NEW RELEASE
B	ENC202308026	2023.08.26	图框变更

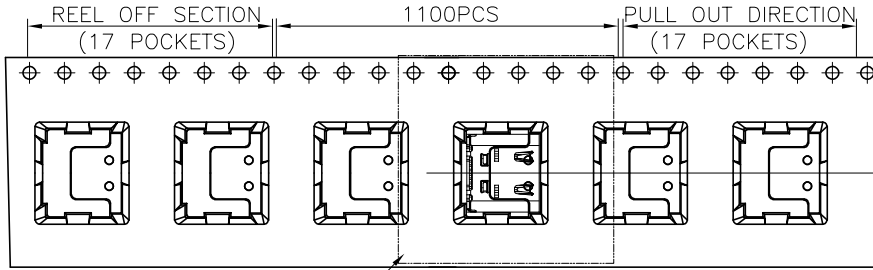

SEE DETAIL X

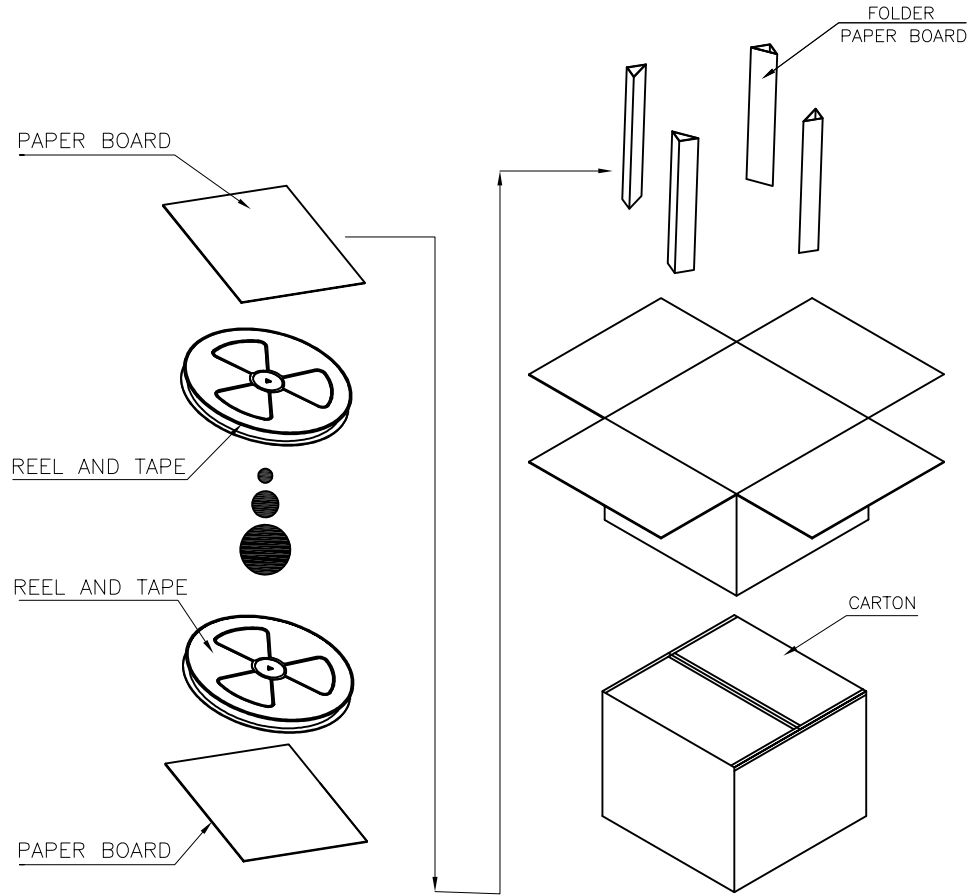
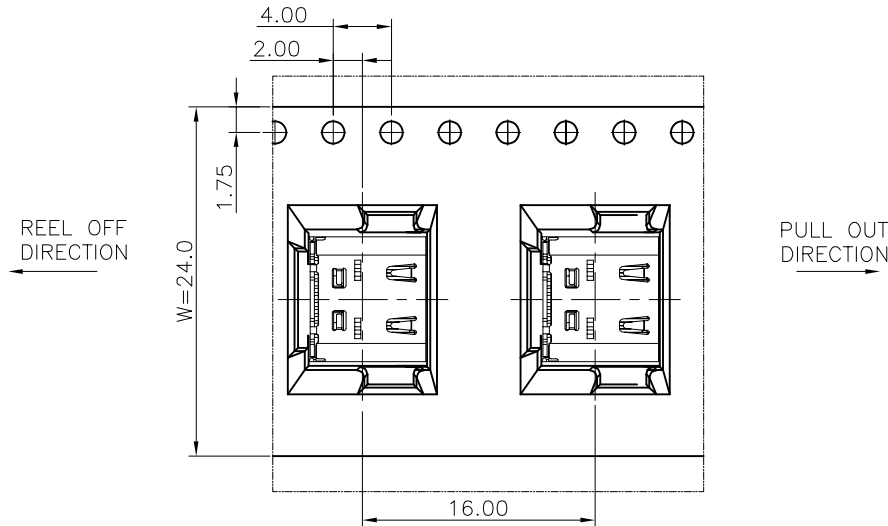
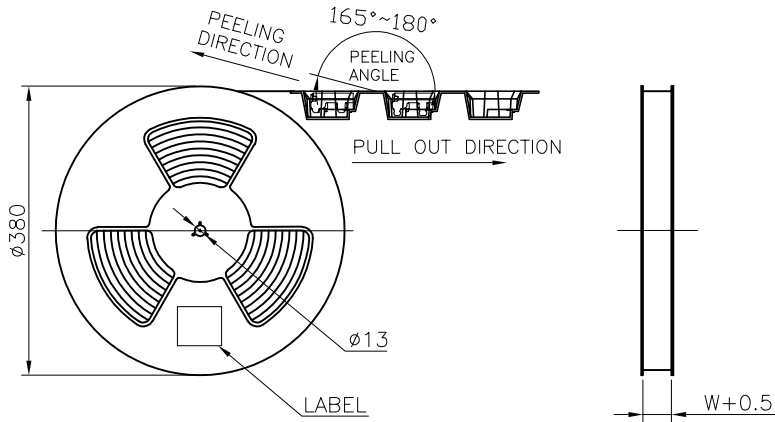

	REEL	CARTON
CONNECTOR (PCS)	1100	11000

PART NO.: SEE THE PART NUMBER CODE		ZDT 深圳市中科兴达科技有限公司 SHENZHEN ZDT TECHNOLOGY CO., LTD		DRAWN BY: SAM	
QUALITY SYMBOL $\nabla = 0$	GENERAL TOLERANCES		TITLE USB 4.0 Type C 24P母座有后盖单壳 双贴SMT板上平贴,L=8.17mm		
	x.xxxx	\pm ---			
	x.xxx	\pm 0.10			
	x.xx	\pm 0.25			
x.x	\pm 0.30	THIRD ANGLE PROJECTION		UNIT mm	SCALE 1:1
ANGULAR	\pm ---	SHEET NO. 3 OF 3		DWG.NO. CF224-010	

frame size: A4