

RoHS Compliant

THIS DRAWING CONTAINS INFORMATION THAT IS PROPRIETARY TO ZDT TECHNOLOGY, AND SHOULD NOT BE USED WITHOUT WRITTEN PERMISSION

REV	ECN No.	DATE	REMARK
A	NEW	2020.12.15	NEW RELEASE
B	---	2023.10.13	8.21尺寸修改8.12与3D相箱

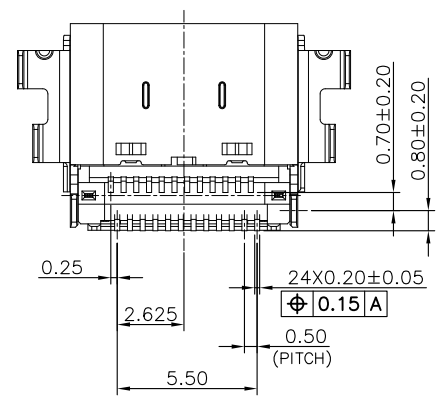
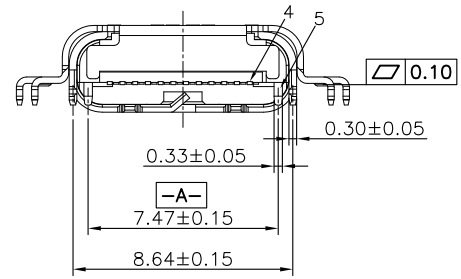
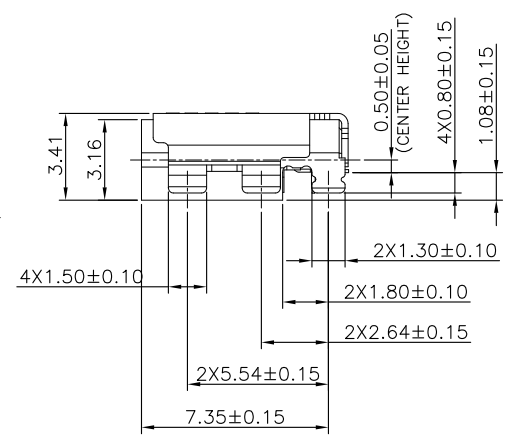
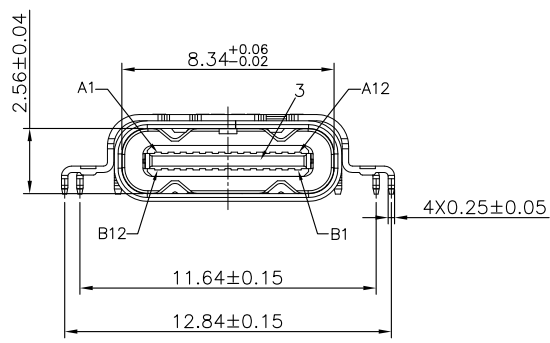
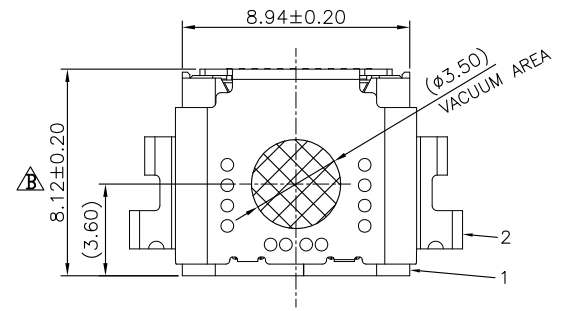
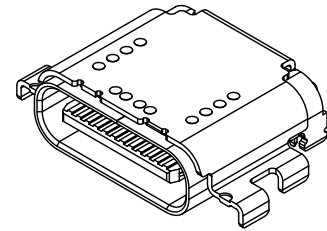

NOTE/注释:  
 1.SPECIFICATION/规格:  
 1.1 Rated current (额定电流): 5.0 A  
 1.2 Voltage rating (额定电压): 5V AC  
 1.3 Contact Resistance (接触阻抗): 40 mΩ Max.  
 1.4 Insulation Resistance (绝缘阻抗): 100MΩ Min.  
 1.5 Withstanding voltage (耐电压): 100 VAC/minute  
 1.6 Mating force (插入力): 5~20N  
 1.7 Unmating force (拔出力): 8~20N.  
 1.8 Durability Cycle(寿命循环):10,000 cycle  
 1.9 Operating temperature (工作温度): -40°~+85°  
 2.PART NUMBER CODE:

CF 3 24 - 013 S X B XX R  
 (1) (2) (3)(4)(5) (6)

- (1) 产品形态:  
3:沉板式
- (2) Pin No.:  
24:24Pin
- (3) HOUSING MATERIALS:  
C:PA9T
- (4) HOUSING COLOR:  
B:BLACK
- (5) CONTACTS PLATED:  
12:接触镀金3u", 其它GF
- (6) PACKING OPTIONS  
R:TAPE & REEL

ITEM	DESCRIPTION	Q'TY	MATERIAL	FINISH	REMARK
4	TERMINAL	24	C18140	MATING SIDE:SEE PART NO; SOLDER TAIL:Gold FLASH, 50u" NICKEL OVERALL.	T=0.12
3	SHELL	1	SUS304	NICKEL PLATING	T=0.30
2	MID PLATE	1	SUS301	NICKEL PLATING	T=0.15
1	MAIN HOUSING	1	PA9T HF 30%玻纤, UL94 V-0, 黑色		BLACK UL94V-0

PART NO.: SEE THE PART NUMBER CODE

**ZDT** 深圳市中科兴达科技有限公司  
SHENZHEN ZDT TECHNOLOGY CO., LTD

QUALITY SYMBOL:

GENERAL TOLERANCES:  
 x.xxxxx ± ---  
 x.xxxx ± 0.10  
 x.xxx ± 0.25  
 x.xx ± 0.30  
 x.x ± ---

TITLE: USB 4.0 Type C24P母座有后盖双壳  
双贴SMT CH=0.5mm,L=8.12mm

THIRD ANGLE PROJECTION

UNIT: mm  
SCALE: 1:1  
SHEET NO.: 1 OF 3

DRAWN BY: SAM  
CHECKED BY: JAY  
APPROVED BY: JACKY

DWG.NO.: CF324-013



RoHS Compliant

THIS DRAWING CONTAINS INFORMATION THAT IS PROPRIETARY TO ZDT TECHNOLOGY. AND SHOULD NOT BE USED WITHOUT WRITTEN PERMISSION

REV	ECN No.	DATE	REMARK
A	NEW	2020.12.15	NEW RELEASE
B	---	2023.10.13	8.21尺寸修改8.12与3D相箱

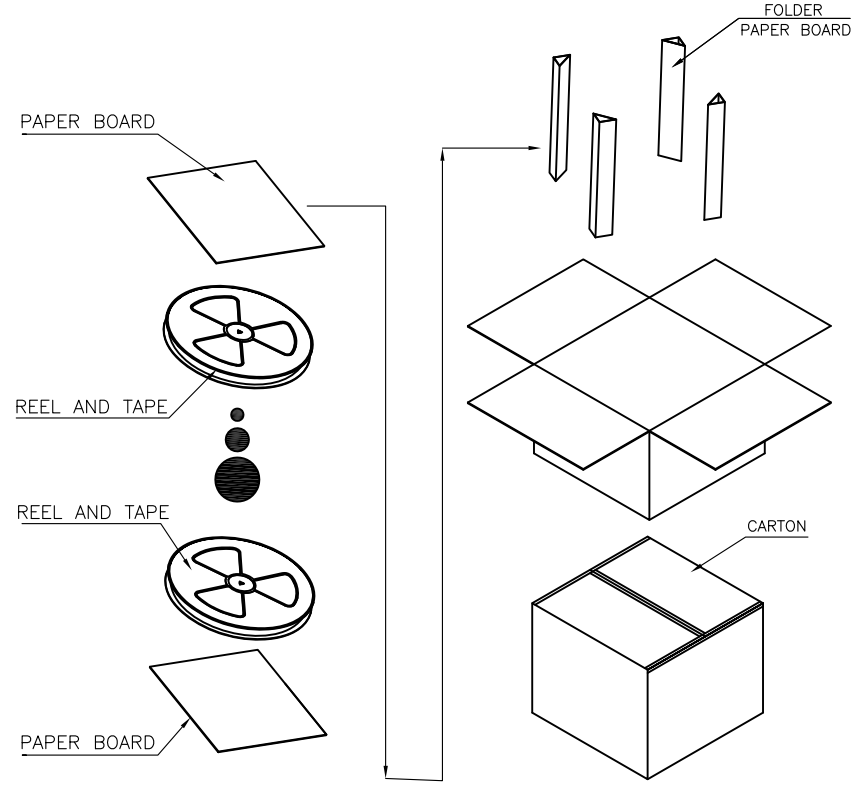
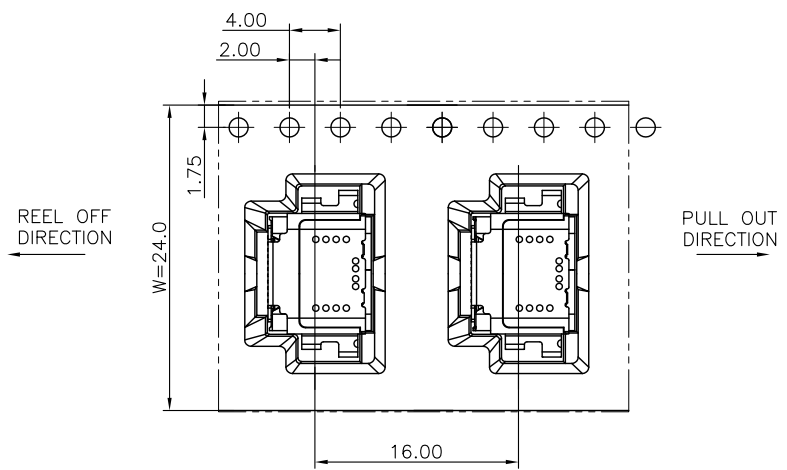
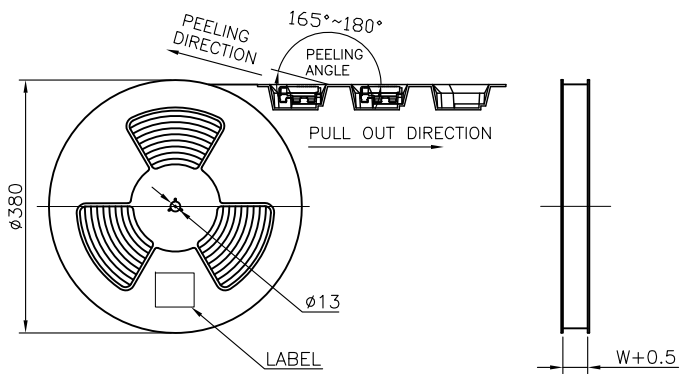
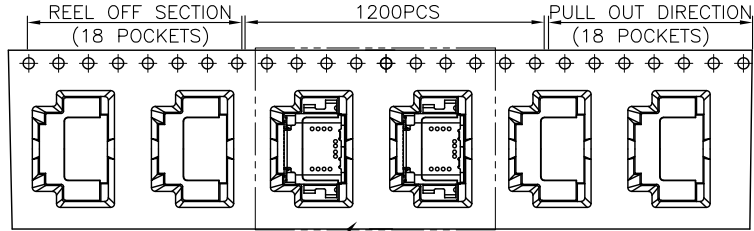

	REEL	CARTON
CONNECTOR (PCS)	1200	12000

PART NO.: SEE THE PART NUMBER CODE		<b>ZDT</b> 深圳市中兴兴达科技有限公司 SHENZHEN ZDT TECHNOLOGY CO., LTD		DRAWN BY: SAM	
QUALITY SYMBOL	○	GENERAL TOLERANCES		CHECKED BY: JAY	
	▽	x.xxxx	± ---	APPROVED BY: JACKY	
	△	x.xxx	± 0.10	DWG.NO. CF324-013	
	□	x.xx	± 0.25	TITLE	
	●	x.x	± 0.30	USB 4.0 Type C24P母座有后盖双壳 双贴SMT CH=0.5mm,L=8.12mm	
▲	ANGULAR	± ---°	THIRD ANGLE PROJECTION	UNIT mm	SCALE 1:1
			SHEET NO. 3 OF 3	frame size: A4	